



SOLVOX[®] mobile – oxygen for water. Flexible and simple solution for capacity increase in small- to medium-sized industrial wastewater treatment plants.



Boosting your plant capacity

Linde's SOLVOX[®] product line has been developed to meet aeration and mixing needs in wastewater treatment plants. The SOLVOX mobile is a flexible solution suitable for all industrial wastewater treatment plants using aeration processes. It can be used to bridge seasonal and production peaks or as a backup solution during maintenance. Its modular concept allows for flexible capacity management and it can be easily stored and installed again when needed. A single unit can oxygenate and mix around 150 to 200 m³ [39,000 to 53,000 US gallons] of wastewater aeration basin volume.

Benefits at a glance

- Portable, lightweight submerged jet dissolver
- Flexible installation to fit any shape of basin: floating or fixed, horizontal or vertical
- Wet installation: no need to drain the tank or halt operation
- Low maintenance and operation costs
- Allows for rapid response to temporary peak loads and maintenance of main aeration equipment

Installation

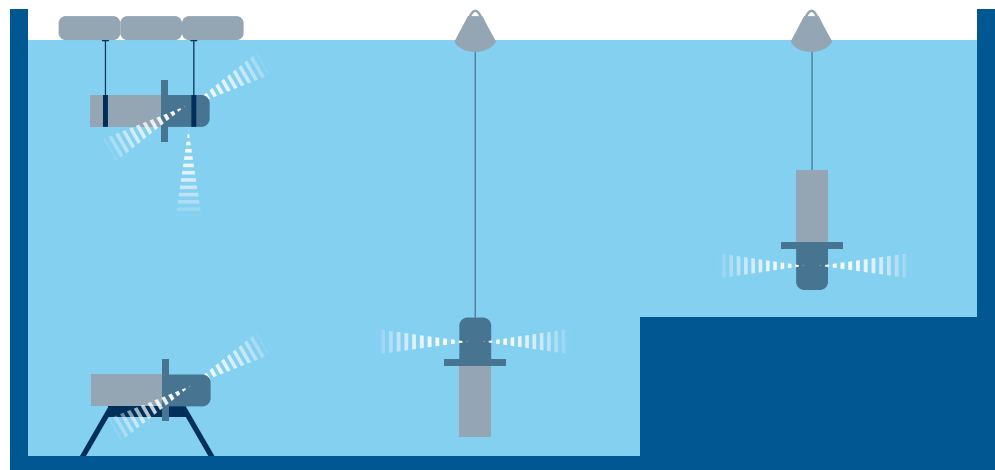

Flexible installation. Submerged venturi mixer for better mixing power and improved dissolved oxygen distribution. Nozzles can be blocked to enable horizontal mounting.

Who can benefit from SOLVOX mobile

- Ideal for small- and medium-sized industrial plants, both with temporary and semi-permanent aeration needs
- Operators who face variable loading or seasonal demand
- Plants with moderate mixing demand that need additional mixing
- Basins with water depth ranging from 3 m to 15 m (10 to 49 ft)

Technical characteristics

SOLVOX mobile	Metric system	Imperial system
Capacity O ₂ /h	10 to 25 kg	22 to 55 lbs
Power rating P1	7,5 kW	10 hp
Power supply	380-400 V / 50 Hz (EU version)	480 V / 60 Hz (US version)
Weight	105 kg	232 lbs
Cable	20 m	66 ft
Head	1,5 barg	218 psi
Total height	1410 mm	4,6 ft
Pump type (IP68)	Centrifugal – radial	Centrifugal – radial
Water temperature max.	45 °C	113 °F
Pump flow	50-60 m ³ /h	13200-15850 gal/h
Minimum immersion	3 m	10 ft
Maximum immersion ¹	15 m	49 ft
Solids diameter	<10 mm	<0.39 in

¹ Allows for 5m (16ft) of cable out of the water.

External features and dimensions

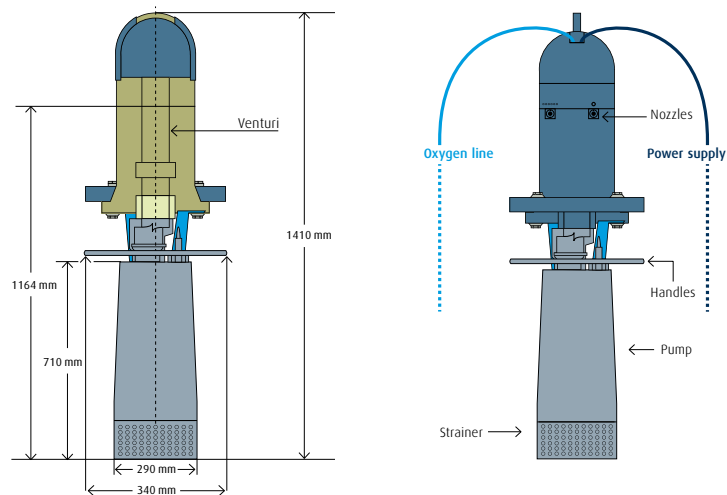

- Four jet nozzles for effective mixing
- High-density polyethylene body (HDPE)
- Patented SOLVOX low-pressure-drop venturi
- Stainless steel pump body
- Low noise level
- No aerosol, noise or foam

Linde GmbH

Gases division, Dr.-Carl-von-Linde-Strasse 6-14, 82049 Pullach, Germany
 Phone: +49 89 7446 0,, watertreatment@linde.com, www.linde-gas.com/watertreatment